



SPM-K30

WALL MOUNT BRACKET

SUPPORT MURAL

デジタルサウンドプロジェクター壁掛け金具

Installation Manual

Manuel d'installation

Installationsanleitung

Instllationsanvisningar

Manuale d'installazione

Manual de instalación

Installatiehandleiding

Руководство по установке

安装说明书

설치 설명서

取付説明書

English

Français

Deutsch

Svenska

Italiano

Español

Nederlands

Русский

中文

한국어

日本語

DIMENSIONS
DIMENSIONS
ABMESSUNGEN
MATTSKISSER
DIMENSIONI
DIMENSIONES

AFMETINGEN
Габариты
各个部分的尺寸
크기
各部分の寸法

Large wall mount bracket
Grand support mural
Große Wandhalterung
Stort väggmonteringsfäste
Staffa di installazione a muro grande
Soporte de montaje en pared grande

Grote wandbevestigingsbeugel
Большой кронштейн настенного крепления
挂壁托架 (大)
대형 벽 마운트 브라켓
壁掛け金具 (大)

■ YSP-800/YSP-900

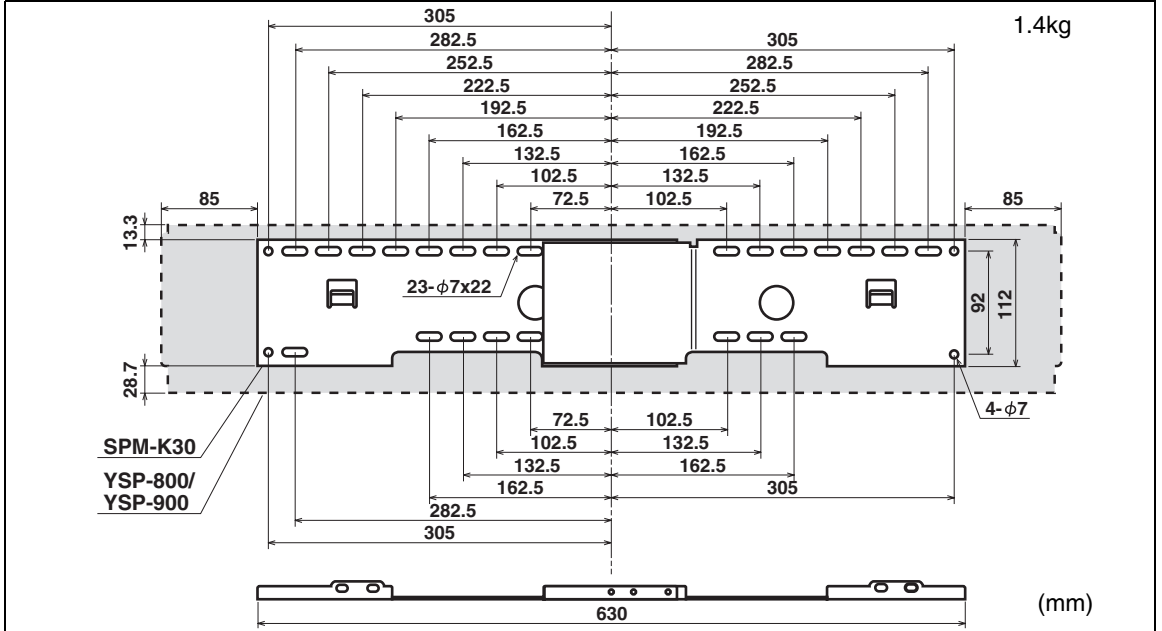

■ YSP-3000/YSP-30D/YSP-3050/HTY-7030

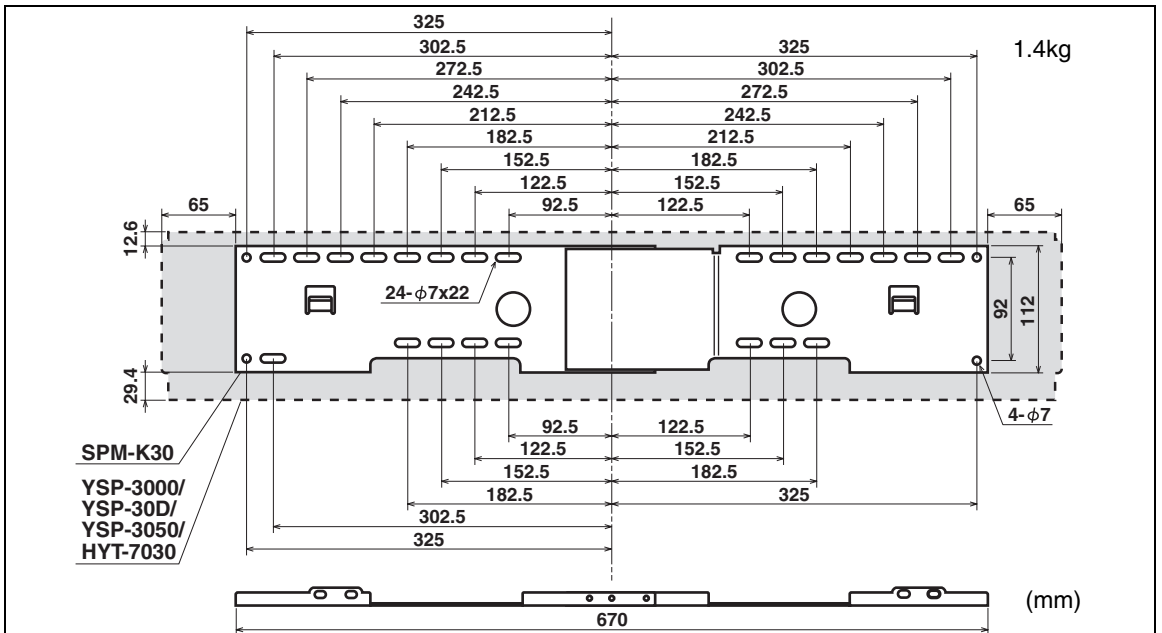

■ YSP-4000/YSP-40D/HTY-7040

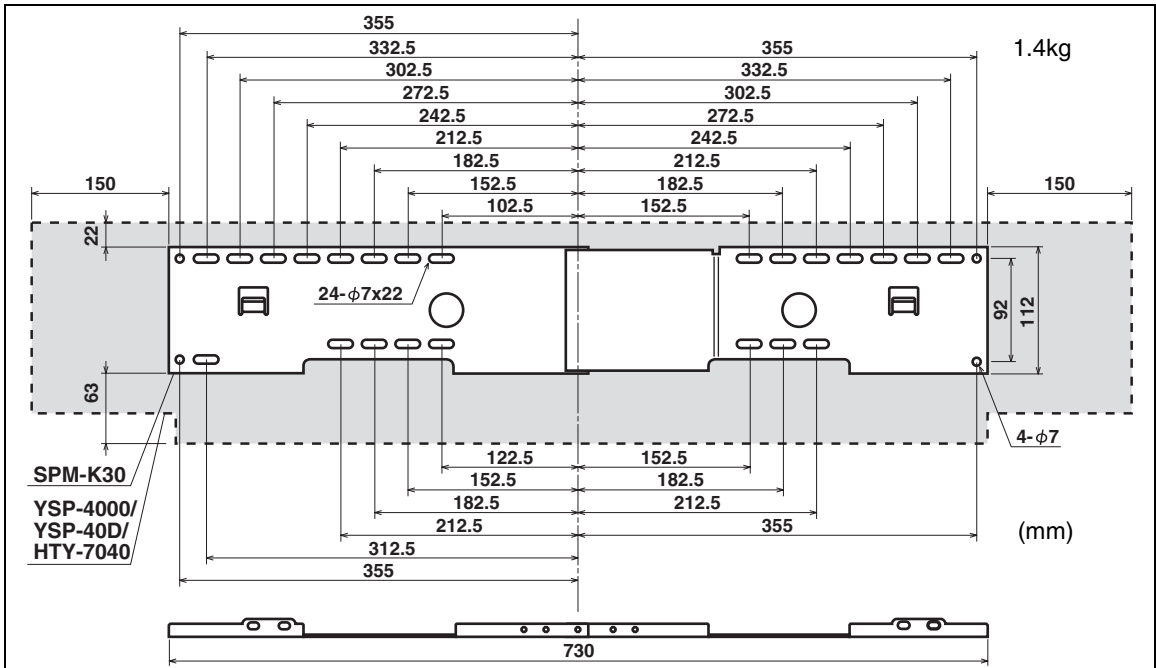

Small wall mount bracket

Petit support mural

Kleine Wandhalterung

Litet väggmonteringsfäste

Staffa di installazione a muro piccola

Soporte de montaje en pared pequeño

Kleine wandbevestigingsbeugel

Малые кронштейны настенного крепления

挂壁托架 (小)

소형 벽 마운트 브라켓

壁掛け金具 (小)

■ A

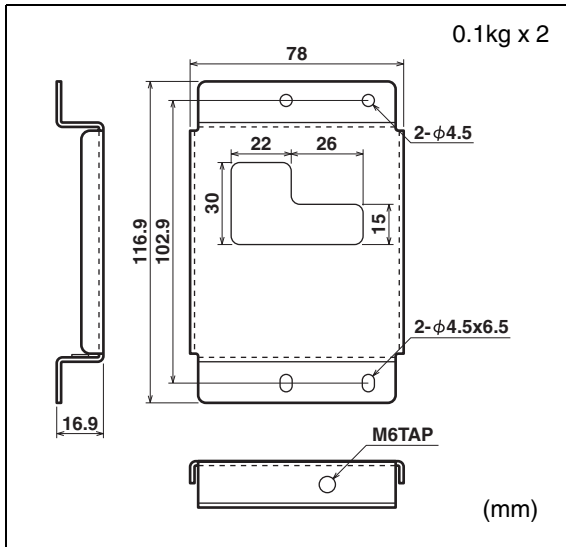

■ B

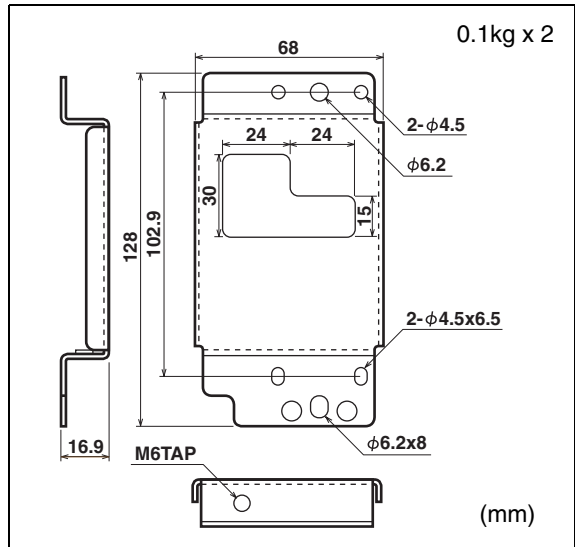

Unit with bracket
Le système avec son support
Einheit mit Halterung
Ljudprojektorn med fästet
Unità con staffa
Unidad con ménsula

Toestel met de beugel
Аппарат с кронштейном
悬挂时尺寸
브라켓이 있는 기기
取付時の寸法

■ YSP-800/YSP-900

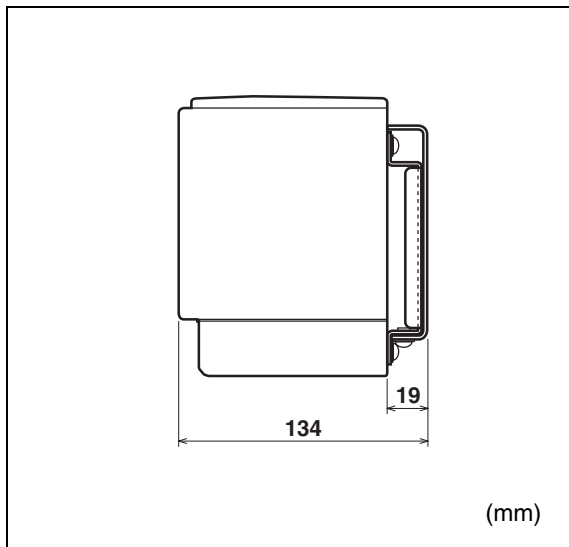

■ YSP-3000/YSP-30D/YSP-3050/HTY-7030

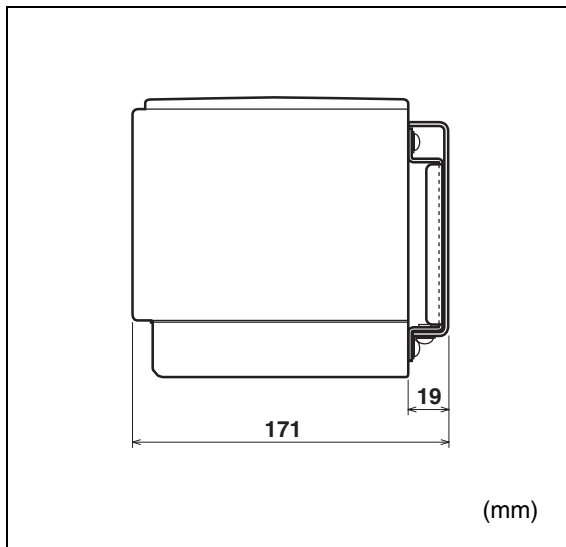

■ YSP-4000/YSP-40D/HTY-7040

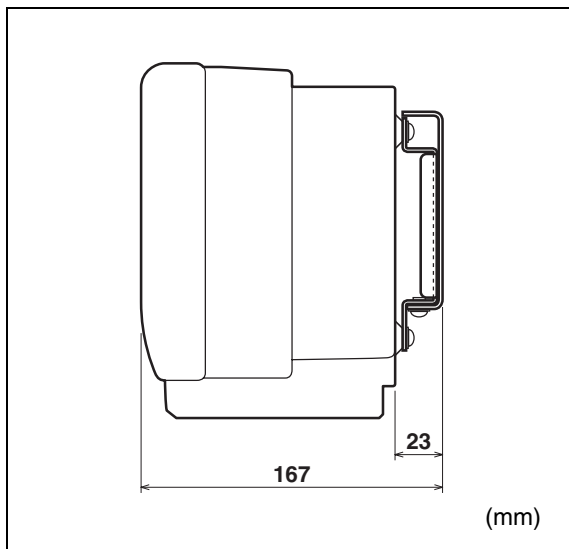

WALL MOUNT BRACKET

SPM-K30

Installation Manual

Thank you very much for purchasing the Wall Mount Bracket SPM-K30. Be sure to read this manual thoroughly before using this bracket. After you have read this manual, retain it for future reference.

When installing the Digital Sound Projector using this bracket, all installation work must be performed by a qualified contractor or dealer personnel. The customer must never attempt to perform this installation work. Improper or inadequate installation could cause the Digital Sound Projector to fall, resulting in personal injury.

SAFETY INSTRUCTIONS

- **Always follow the instructions set forth in this manual when installing the Digital Sound Projector using this bracket.**
Improper or inadequate installation could cause the Digital Sound Projector to fall, resulting in personal injury.
- **The installation must be secure enough to bear the weight of the Digital Sound Projector, the wall bracket and other hardware indefinitely, and must also be secure enough to withstand vibrations.**
Improper or inadequate installation could cause the Digital Sound Projector to fall, resulting in personal injury.
- **To ensure safety, all screws must be tightened securely.**
Loose screws could cause the Digital Sound Projector to fall, resulting in personal injury.
- **Make sure to leave adequate ventilation space around the unit to allow heat generated by the Digital Sound Projector to dissipate.**
Failure to provide adequate space around the unit could cause the Digital Sound Projector to overheat internally, resulting in a fire.
- **Never hang from the Digital Sound Projector or the wall bracket.**
Hanging from the Digital Sound Projector or the wall bracket could cause the Digital Sound Projector or the wall bracket to fall, resulting in personal injury.
- **Once the Digital Sound Projector is installed, safety checks should be conducted on a regular basis.**
If the Digital Sound Projector is used over an extended period of time, screws can become loose and the installation can become weaker due to the passage of time, vibrations, etc.

ACCESSORIES

Check that all of the following parts are included.

Large wall mount bracket (LEFT) (x1)

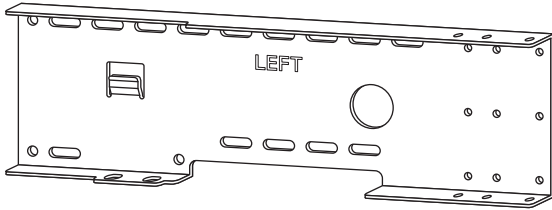

Large wall mount bracket (RIGHT) (x1)

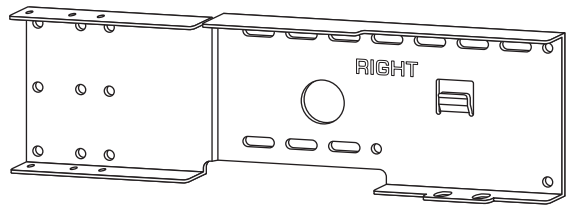

Small wall mount brackets
(Type A) (x2)

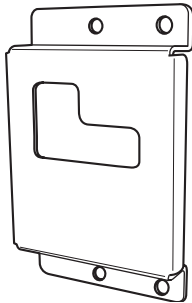

Small wall mount brackets
(Type B) (x2)

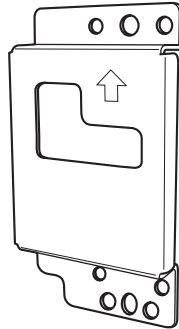

Safety wires (x2)

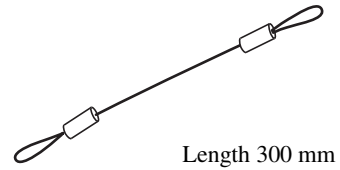

Projector mounting screws
(M6, 16 mm) (x6)



Projector mounting screws
(M4, 10 mm) (x10)



Washers (for M6, 16 mm of
outer circumference) (x4)



Note

Prepare at least six sets of commercially available tapping screws ($\phi 4$ mm, 25 mm or more in length) and washers in addition to the accessories shown above.

ASSEMBLING PROCEDURE

The dimensions after assembling the parts vary depending on the type of the Digital Sound Projector. Check the positions of the screw holes before assembling the parts.

YSP-800, YSP-900

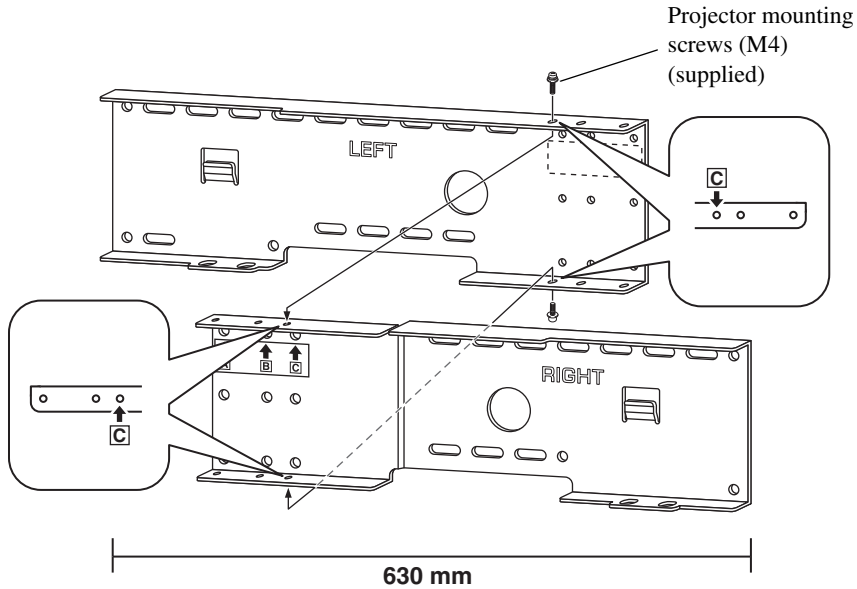

YSP-3000, YSP-30D, YSP-3050, HTY-7030

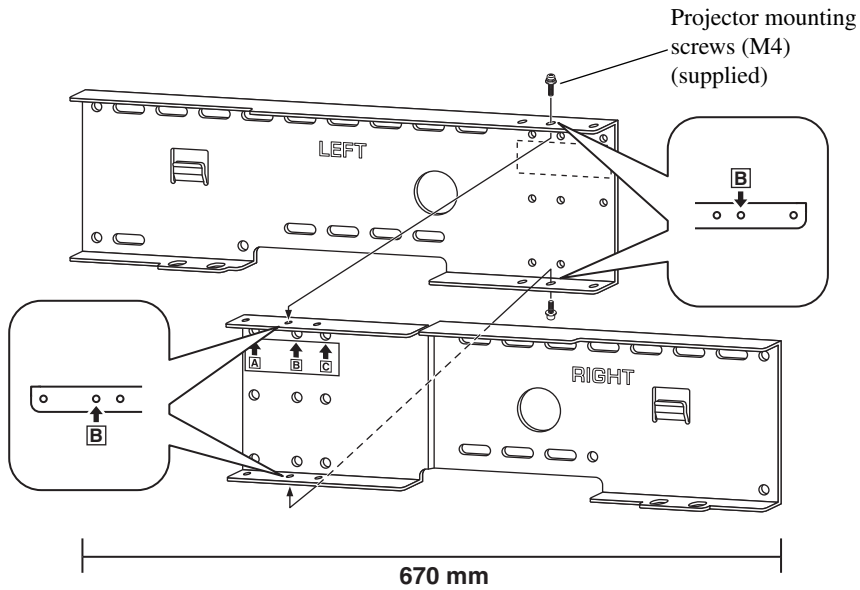

YSP-4000, YSP-40D, HTY-7040

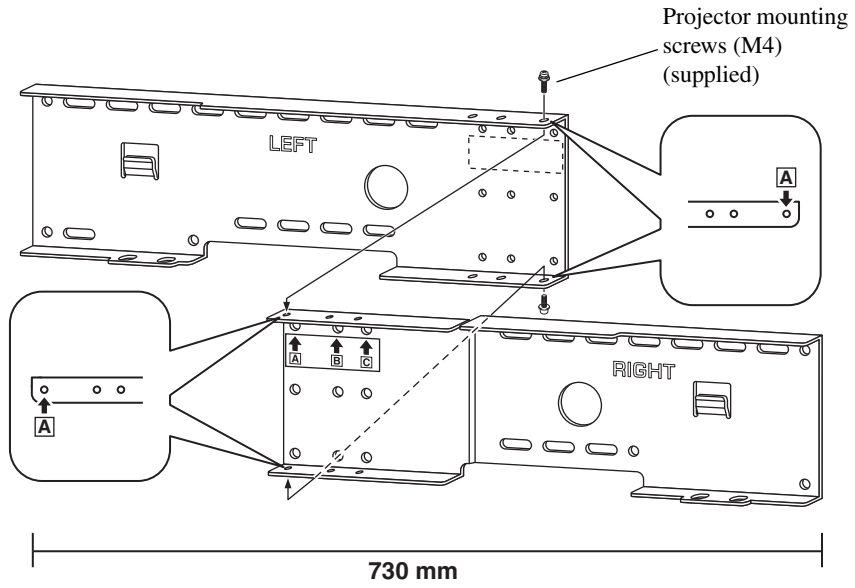

INSTALLATION PROCEDURE

Make sure to leave adequate ventilation space around the unit and follow the instructions below. The illustrations used in each step are the examples of YSP-800 and YSP-900.

1 Attach the large wall mount bracket to the wall.

In order to secure the unit to the wall, you will need to attach the bracket to the wall first in a manner befitting the structure and quality of the wall.

Choose a location where the wall can bear the weight of the whole unit.

Before installing the bracket, make sure of the size (see "DIMENSIONS" on the first page of this manual).

Installation example

4 mm Tapping Screw (commercially available)

In order to secure the unit to the wall, drive six (or more) tapping screws from the outside through the holes in the wall mount bracket.

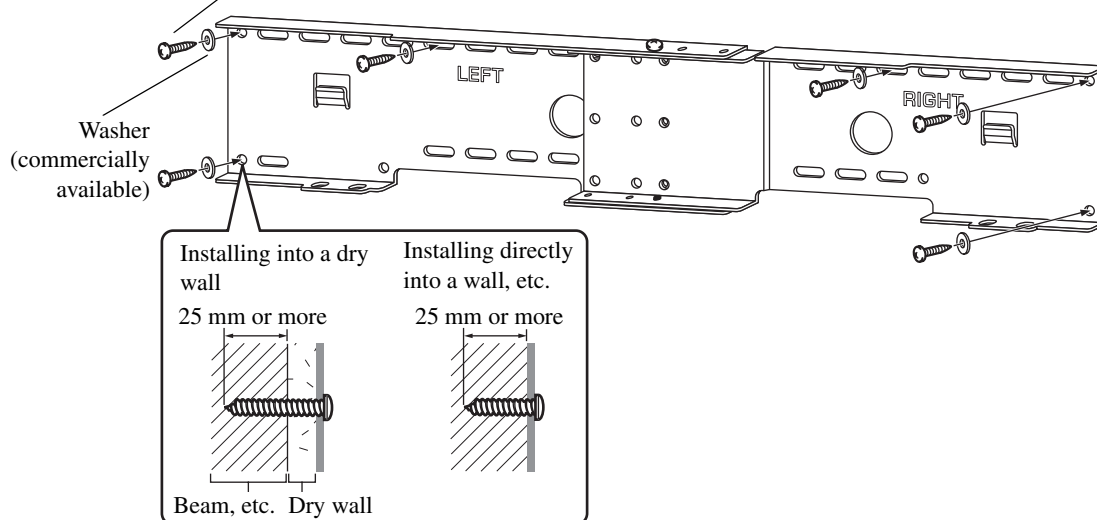

Note

Choose a secure wall or beam to fasten the screws. Do not install them into walls made of weak material that can easily come off, such as mortar or plywood wall panels. Loose screws could cause the projector to fall, resulting in personal injury.

2 Detach the metal apparatuses from the Digital Sound Projector. (Some models of YSP-800 only)

If the metal apparatuses are attached to the rear panel of your Digital Sound Projector, detach them from the rear left and right sides. If the metal apparatuses are not attached to the rear panel of your Digital Sound Projector, proceed to step 3.

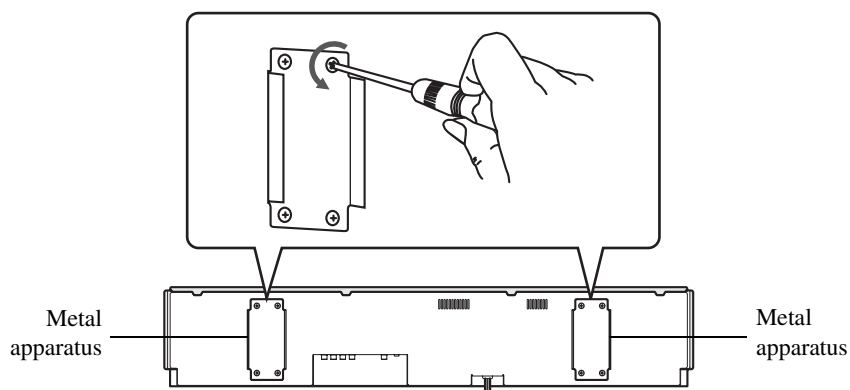

3 Attach the small wall mount brackets to the Digital Sound Projector.

The small wall mount brackets vary depending on the type of the Digital Sound Projector. Refer to the following table for details on the type of the Digital Sound Projector and the compatible small wall mount brackets (Type A or B). Use supplied projector mounting screws (M6 x 4 for YSP-4000, YSP-40D or HTY-7040 and M4 x 8 for other models) to securely attach the two small wall mount brackets to the rear left and right sides of the Digital Sound Projector.

Digital Sound Projector	Small wall mount bracket
YSP-800 YSP-900	Type A
YSP-3000 YSP-30D YSP-3050 HTY-7030 YSP-4000 YSP-40D HTY-7040	Type B

Attach the brackets to the rear left and right sides of the Digital Sound Projector.

■ YSP-4000/YSP-40D/HTY-7040

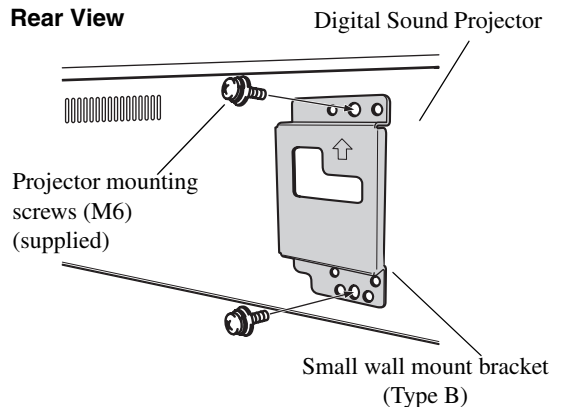

■ YSP-3000/YSP-30D/HTY-7030/ YSP-3050

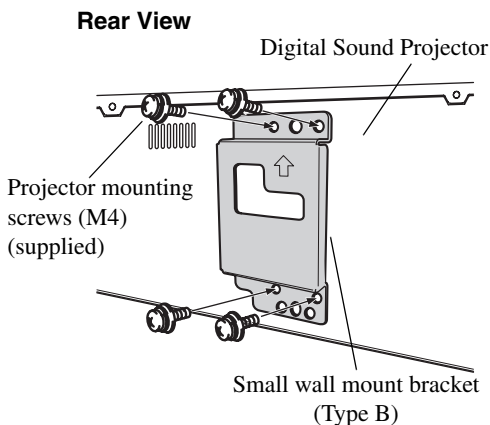

■ YSP-800/YSP-900

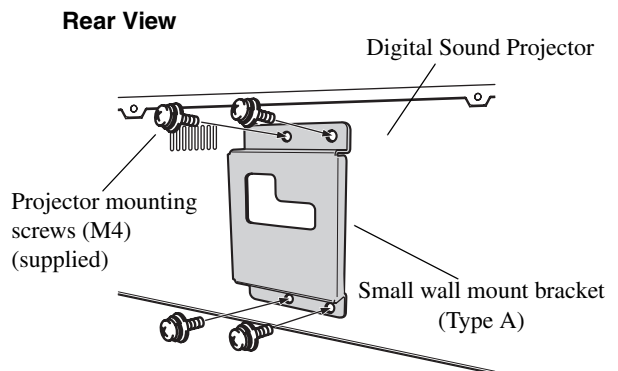

Notes

- In the unit of the model that the metal apparatuses are not attached, there are felt covers in the holes. In this case, tighten the screws to puncture the felt covers.
- If you tighten the screws on the slant, the screw threads in the projector might be broken. Be careful when using electric tools.

4 Attach the safety wire.

Attach the safety wire to the small wall mount bracket to prevent the Digital Sound Projector from falling.

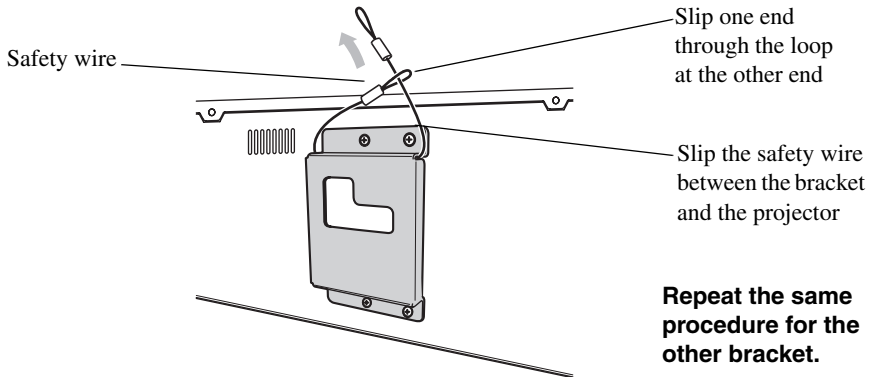

5 Mount the Digital Sound Projector on the wall.

Fit the mounting guide hooks of the small wall mount brackets attached to the Digital Sound Projector into the holes on the left and right sides of the large wall mount bracket and then slide the unit to the right.

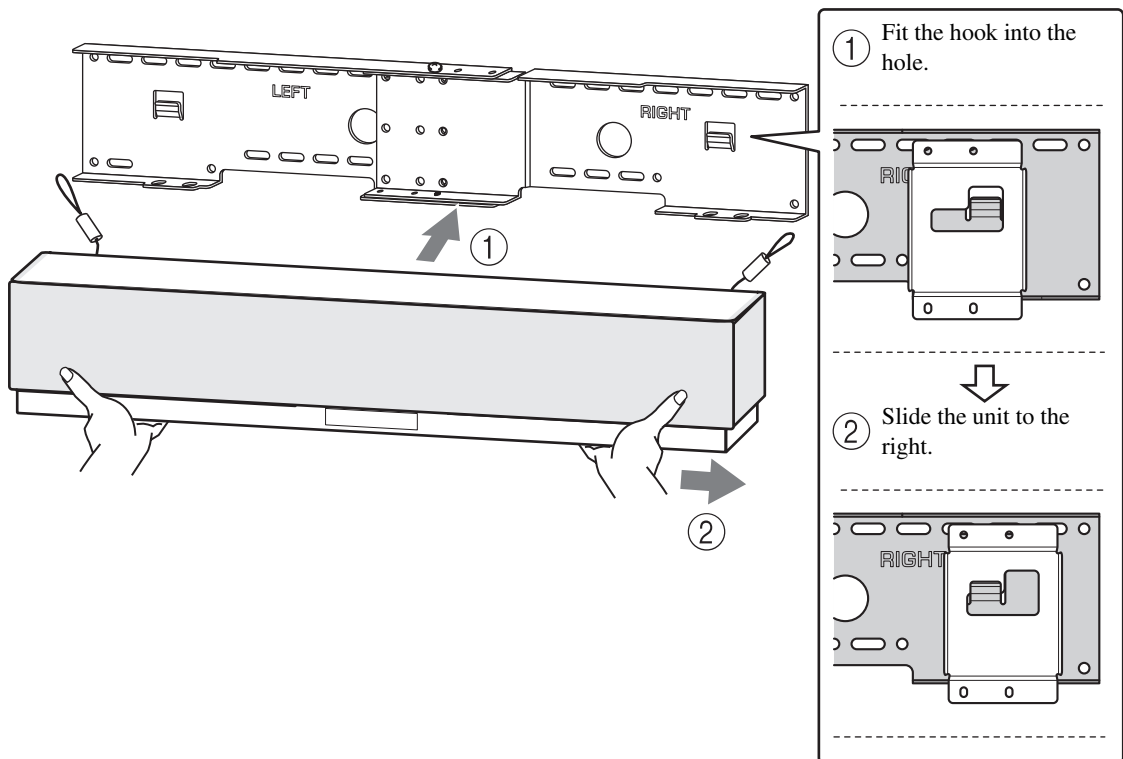

Note

Hold the Digital Sound Projector tight with both hands when attaching or removing the Digital Sound Projector to or from the wall. Holding the Digital Sound Projector loosely could cause the Digital Sound Projector to fall, resulting in personal injury.

6 Secure the unit.

Align the holes in the large wall mount bracket with the holes in the bottom of the small wall mount brackets, and then use two of the supplied projector mounting screws (M6 x 16) to secure the unit. The positions of the screw holes vary depending on the type of the Digital Sound Projector. Refer to the following illustrations and check the correct positions of the screw holes used to secure your Digital Sound Projector.

■ YSP-800/YSP-900

Digital Sound Projector **Bottom View**

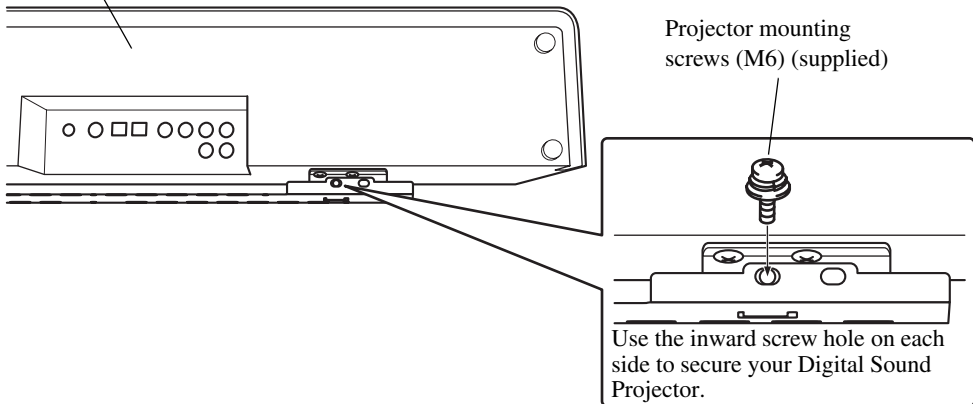

■ YSP-3000/YSP-30D/YSP-3050/HTY-7030/ YSP-4000/YSP-40D/HTY-7040

Digital Sound Projector **Bottom View**

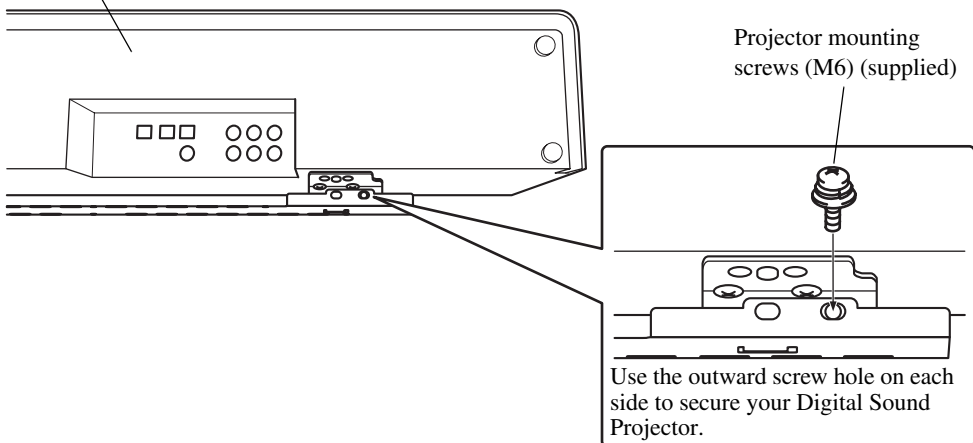

7 Attach the safety wires to the wall.

Pass the screws (commercially available) through the loops of the safety wires and then tighten the screws to secure the safety wires to the wall.

Make sure that the screws are strong enough to bear the weight of the Digital Sound Projector and the brackets in case they fall.

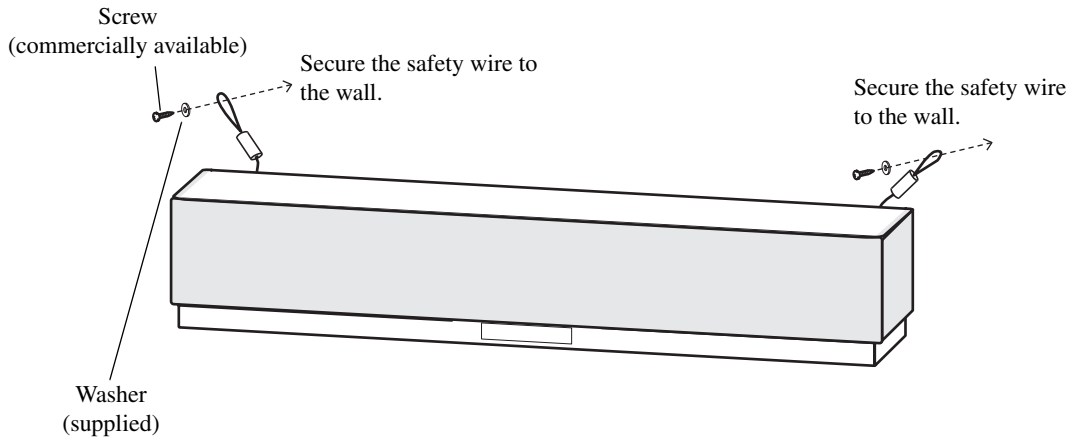

Notes

- **Attach the safety wires tight.**
- **Keep the 2 other washers for future use.**

Limited Guarantee for European Economic Area (EEA) and Switzerland

Thank you for having chosen a Yamaha product. In the unlikely event that your Yamaha product needs guarantee service, please contact the dealer from whom it was purchased. If you experience any difficulty, please contact Yamaha representative office in your country. You can find full details on our website (www.yamaha-hifi.com/ or www.yamaha-uk.com/ for U.K. resident).

The product is guaranteed to be free from defects in workmanship or materials for a period of two years from the date of the original purchase. Yamaha undertakes, subject to the conditions listed below, to have the faulty product or any part(s) repaired, or replaced at Yamaha's discretion, without any charge for parts or labour. Yamaha reserves the right to replace a product with that of a similar kind and/or value and condition, where a model has been discontinued or is considered uneconomic to repair.

Conditions

1. The original invoice or sales receipt (showing date of purchase, product code and dealer's name) **MUST** accompany the defective product, along with a statement detailing the fault. In the absence of this clear proof of purchase, Yamaha reserves the right to refuse to provide free of charge service and the product may be returned at the customer's expense.
2. The product **MUST** have been purchased from an **AUTHORISED** Yamaha dealer within the European Economic Area (EEA) or Switzerland.
3. The product must not have been the subject of any modifications or alterations, unless authorised in writing by Yamaha.
4. The following are excluded from this guarantee:
 - a. Periodic maintenance and repair or replacement of parts due to normal wear and tear.
 - b. Damage resulting from:
 - (1) Repairs performed by the customer himself or by an unauthorised third party.
 - (2) Inadequate packaging or mishandling, when the product is in transit from the customer. Please note that it is the customer's responsibility to ensure the product is adequately packaged when returning the product for repair.
 - (3) Misuse, including but not limited to (a) failure to use the product for its normal purpose or in accordance with Yamaha's instructions on the proper use, maintenance and storage, and (b) installation or use of the product in a manner inconsistent with the technical or safety standards in force in the country where it is used.
 - (4) Accidents, lightning, water, fire, improper ventilation, battery leakage or any cause beyond Yamaha's control.
 - (5) Defects of the system into which this product is incorporated and/or incompatibility with third party products.
 - (6) Use of a product imported into the EEA and/or Switzerland, not by Yamaha, where that product does not conform to the technical or safety standards of the country of use and/or to the standard specification of a product sold by Yamaha in the EEA and/or Switzerland.
 - (7) Non AV (Audio Visual) related products.
(Products subject to "Yamaha AV Guarantee Statement" are defined in our website at www.yamaha-hifi.com/ or www.yamaha-uk.com/ for U.K. resident.)
5. Where the guarantee differs between the country of purchase and the country of use of the product, the guarantee of the country of use shall apply.
6. Yamaha may not be held responsible for any losses or damages, whether direct, consequential or otherwise, save for the repair or replacement of the product.
7. Please backup any custom settings or data, as Yamaha may not be held responsible for any alteration or loss to such settings or data.
8. This guarantee does not affect the consumer's statutory rights under applicable national laws in force or the consumer's rights against the dealer arising from their sales/purchase contract.

ヤマハホットラインサービスネットワーク

ヤマハホットラインサービスネットワークは、本機を末永く、安心してご愛用いただくためのものです。サービスのご依頼、お問い合わせは、お買い上げ店、またはお近くのサービス拠点にご連絡ください。

ヤマハAV製品の機能や取り扱いに関するお問い合わせ

■ ヤマハオーディオ&ビジュアルホームページ

お客様から寄せられるよくあるご質問をまとめておりますので、ご参考にしてください。

<http://www.yamaha.co.jp/audio/>

■ AVお客様ご相談センター



0570-01-1808

全国どこからでも市内通話料金でご利用いただけます。

携帯電話、PHS、IP電話からは下記番号におかけください。
TEL (053) 460-3409

FAX (053) 460-3459
〒430-8650 静岡県浜松市中区中沢町10-1

受 付 日：月～土曜日(祝日およびセンターの休業日を除く)
受付時間：10:00～12:00、13:00～18:00

ヤマハAV製品の修理、サービスパーツに関するお問い合わせ

■ ヤマハ電気音響製品修理受付センター

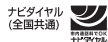

0570-01-2808

全国どこからでも市内通話料金でご利用いただけます。

携帯電話、PHS、IP電話からは下記番号におかけください。
TEL (053) 460-4830

FAX (053) 463-1127

受 付 日：月～土曜日(祝日およびセンターの休業日を除く)
受付時間：月～金曜日 9:00～19:00 土曜日 9:00～17:30

修理お持ち込み窓口

受 付 日：月～金曜日(祝日および弊社の休業日を除く)
受付時間：9:00～17:45

北海道 〒064-8543 札幌市中央区南10条西1丁目1-50
ヤマハセンター内
FAX (011) 512-6109

首都圏 〒143-0006 東京都大田区平和島2丁目1-1
京浜トラクターミナル内14号棟A-5F
FAX (03) 5762-2125

浜松 〒435-0016 浜松市東区和田町200
ヤマハ(株)和田工場内
FAX (053) 462-9244

名古屋 〒454-0058 名古屋市中川区玉川町2丁目1-2
ヤマハ(株)名古屋倉庫3F
FAX (052) 652-0043

大阪 〒564-0052 吹田市広芝町10-28
オーク江坂ビルディング2F
FAX (06) 6330-5535

九州 〒812-8508 福岡市博多区博多駅前2丁目11-4
FAX (092) 472-2137

*名称、住所、電話番号、URLなどは変更になる場合があります。

Above information is applicable to customers who live in Japan only.
ヤマハホットラインサービスネットワークは、日本国内居住のお客様専用です。



● 保証期間

お買い上げ日から1年間です。

● 保証期間中の修理

保証書の記載内容に基づいて修理させていただきます。詳しくは保証書をご覧ください。

● 保証期間が過ぎているとき

修理によって製品の機能が維持できる場合にはご要望により有料にて修理いたします。

● 修理料金の仕組み

技術料 故障した製品を正常に修復するための料金です。技術者の人件費、技術教育費、測定機器等設備費、一般管理費等が含まれています。

部品代 修理に使用した部品代金です。その他修理に付帯する部材等を含む場合もあります。

出張料 製品のある場所へ技術者を派遣する場合の費用です。別途、駐車料金をいただく場合があります。

● 補修用性能部品の最低保有期間

補修用性能部品の最低保有期間は、製造打ち切り後8年です。補修用性能部品とは、その製品の機能を維持するために必要な部品です。

● 製品の状態は詳しく

サービスをご依頼されるときは製品の状態をできるだけ詳しくお知らせください。また製品の品番、製造番号などもあわせてお知らせください。
※ 品番、製造番号は製品の背面もしくは底面に表示してあります。

● スピーカーの修理

スピーカーの修理可能範囲はスピーカーユニットなど振動系と電気部品です。尚、修理はスピーカーユニット交換となりますので、エージングの差による音色の違いが出る場合があります。

● 摩耗部品の交換について

本機には使用年数とともに性能が劣化する摩耗部品(下記参照)が使用されています。摩耗部品の劣化の進行度合は使用環境や使用時間等によって大きく異なります。

本機を末永く安定してご愛用いただくためには、定期的に摩耗部品を交換されることをおすすめします。

摩耗部品の交換は必ずお買い上げ店、またはヤマハ電気音響製品修理受付センターへご相談ください。

摩耗部品の一例

ボリュームコントロール、スイッチ・リレー類、接続端子、ランプ、ベルト、ピンチローラー、磁気ヘッド、光ヘッド、モーター類など

※ このページは、安全にご使用いただくためにAV製品全般について記載しております。

永年ご使用の製品の点検を!



愛情点検

こんな症状はありませんか?

- 電源コード・プラグが異常に熱い。
- コゲくさい臭いがある。
- 電源コードに深いキズか変形がある。
- 製品に触れるとビリビリと電気を感ずる。
- 電源を入れても正常に作動しない。
- その他の異常・故障がある。



すぐに使用を中止してください。

事故防止のため電源プラグをコンセントから抜き、必ず販売店に点検をご依頼ください。
なお、点検・修理に要する費用は販売店にご相談ください。